

**FACIT**

Tape punch    Technical description

## APPLICATIONS



Manually operated data recording system

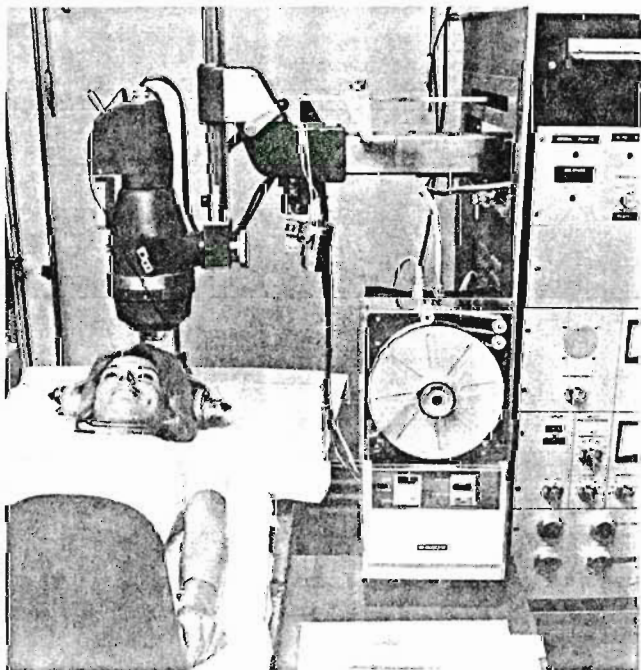

Hospital systems — quiet and compact

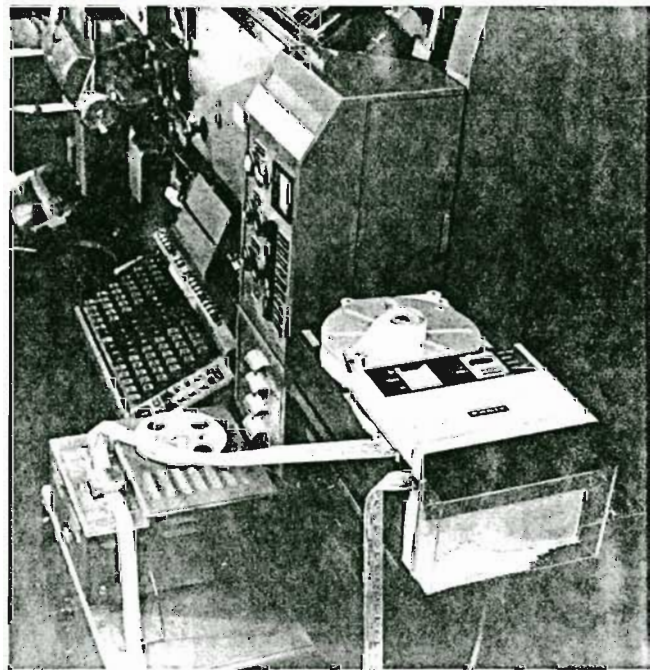

Typesetting

## GENERAL

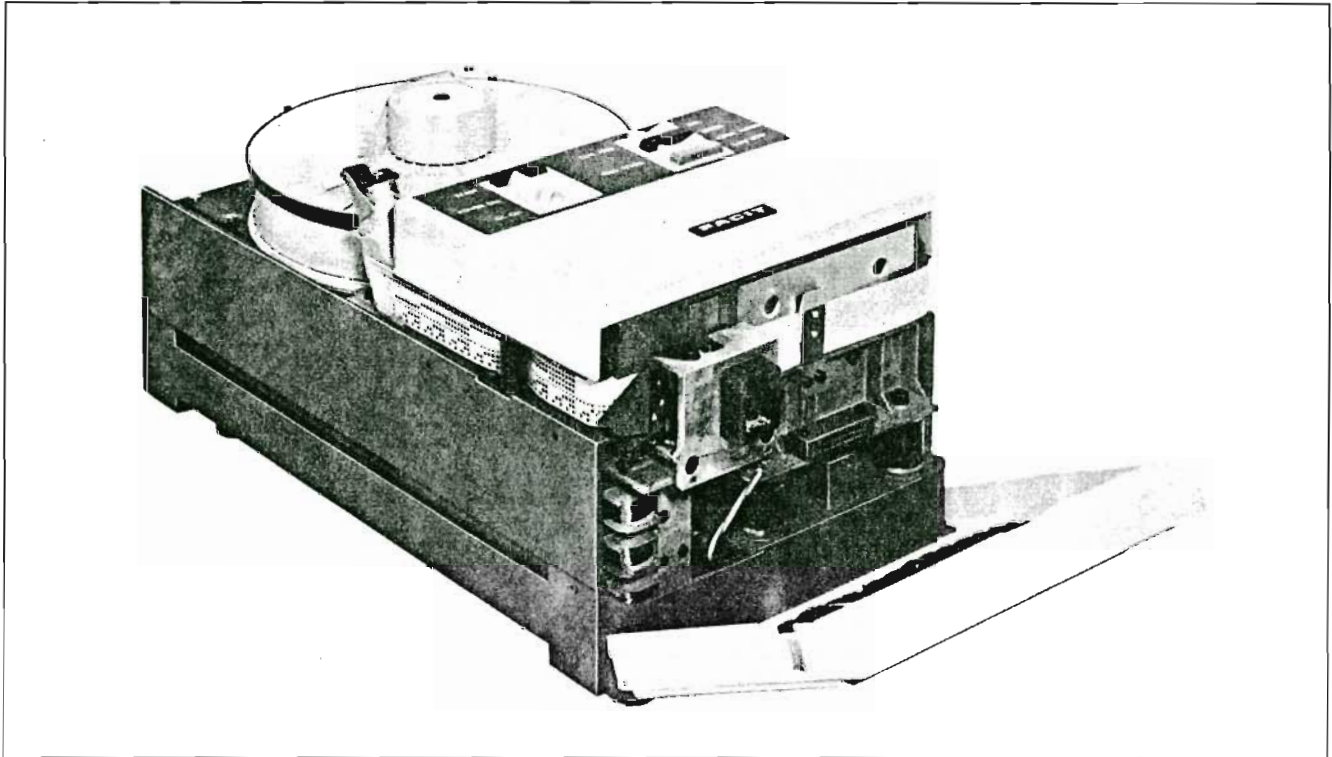

Fig. 1 Facit 4070 tape punch with the front lid opened

The Facit 4070 is a compact, quiet-running tape punch operating at speeds up to 75 characters per second. It punches all types of standard tape for 5, 6, 7 or 8 tracks and is also available for punching 6-track typesetting tape. It is well suited for data recording in conjunction with such manually operated input units as typewriters, calculators, accounting machines, etc., for all kinds of data recording applications and as computer peripheral.

The Facit 4070 tape punch consists of three main sections: the punching and feeding unit, the tape supply and take-up unit and the control circuitry. The punching and feeding unit is easily exchangeable. It includes a motor for incremental feed of the tape by means of a capstan and a punching mechanism with solenoid-actuated punching pins. Only a few moving parts are used, reducing maintenance to a minimum. The punched tape may either be wound up in the tape punch on the take-up flange or collected in a basket. Take-up direction is optional. All electronics are built on a standard printed circuit board containing integrated circuits. Underneath the standard board there is space for an additional matching board. This board can be supplied without components, to be used by the customer for his own interface electronics. The board can be inserted directly in the space for the matching board where it is supplied with d.c. voltages from the built-in power supply. No internal changes to wiring are necessary. Part of this board can also be equipped with parity check, echo check or other types of

checking circuits. These checks cover the data path from punch unit inputs to the windings of the punch solenoids.

A control panel is located on the top of the punch. This panel also contains voltage supply and tape check pilot lamps. If the mains voltage supplied to the punch falls below a certain level the current to the punching solenoids is automatically interrupted to eliminate punching errors. Additionally, the amount of tape left on the supply flange is checked and a lamp lights up when the tape is nearing the end.

Input data is gated to the punch in parallel with a punching signal. Punching speed is determined by the punching signal and can be varied between 0 and 75 characters per second. While punching is in progress the punch emits a busy signal which also indicates that data has been stored in a buffer register in the tape punch.

Direction of tape feed is determined by a control signal to the punch. This also enables the tape to be moved backwards a number of steps which permits a correction, e.g. by overpunching in manual routines.

Some practical accessories are available for the tape punch. The tape punch on the cover picture for example is fitted with a chad box at the front, and a protective plastic cover at the top.

## DESIGN AND CONSTRUCTION

Fig. 1 on page 3 shows the punch with tape inserted and the front lid opened.

Part of the punching mechanism with incremental motor and tape holder can be glimpsed behind the front lid. The tape holder accommodates to the tape width in use.

At the rear of the punch can be seen the supply and take-up flanges, the take-up flange uppermost. The take-up flange is easily removed to facilitate tape loading. From the supply flange the tape runs past three guide rollers, two of which are fixed while the third is mounted on a movable arm which senses tape movement. The tape "climbs" up a tape lifter from the lower level to the take-up flange. This tape lifter is provided with a retractable tape tearer. Another tape tearer is located at the point where the tape emerges from the punching unit, for tearing off the tape when it is collected in a basket.

A separate motor drives the take-up flange and can be set for clockwise or anti-clockwise rotation.

The control panel on the top of the punch is fitted with the following switches and lamps:

POWER ON:	Switches on mains supply.
DC ON:	Switches on internal DC supply.
READY:	Pilot lamp — lights up when internal DC is switched on.
TAPE FEED:	Feed virgin tape (without any holes).
EXT:	May be used for signalling to data input source — "transmit data", "clear", etc.
ERROR:	Pilot lamp — lights up when tape breaks or tightens.
FEED HOLES:	Feeds blank tape (with feed holes).
CODE HOLES:	Feeds tape with customer-selected mark character.
TAPE LOW:	Pilot lamp — lights up when tape nearing end.

The tape punch features built-in control logic circuits for synchronizing tape feed and punching operations. Logic circuits are incorporated on the plug-in standard board at the bottom of the punch. Facilities are also provided for transmitting external signals to the punch for moving the tape backwards (max. 10 steps depending upon tape quality).

The Facit 4070 is available for operation on d.c. or on a.c. mains supplies. The a.c. version is reconnectable for 100/115/220/240 volts by means of a selector switch on the rear of the control panel. The d.c. version of the punch is powered by a 24-volt supply such as from a battery. A d.c. version is also available for 48/60. Designed especially for telephone exchange applications. The previously mentioned internal check of mains supply then monitors the battery voltage.

Signal and power connections are at the rear of the tape punch (see back cover). At bottom is the extra space for the matching printed circuit board.

## Rack-mounted tape punch

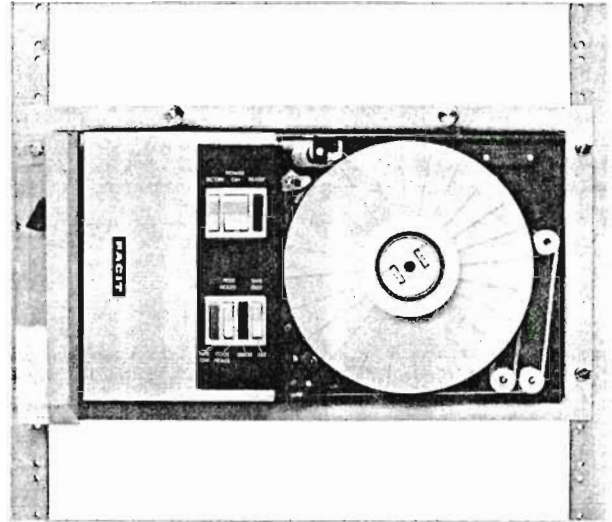

Fig. 2 Rack mounted tape punch

The Facit 4070 is also available in a 19" rack-mounted version. The text on the control panel is turned for easy readability. The specially designed chad box replaces the front lid to ensure optimum air cooling for the punch read unit. The chad box must thus always be in place when the punch is operating.

## Adapter for fan-folded tape handling

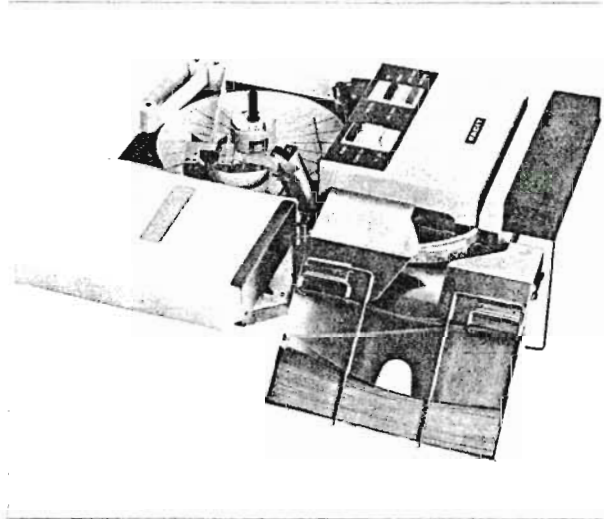

Fig. 2 b Adapted for fan-folded tape handling

All table-top models of the Facit 4070 can be equipped with an adapter for fan-folded tape handling. It is easily fitted without modifications by hanging it on the left side of the punch, where it is locked, using two handles. The adapter can accommodate up to 60 metres of fan-folded tape with an inter-fold distance of 216 mm (8 1/2").

## OPERATION

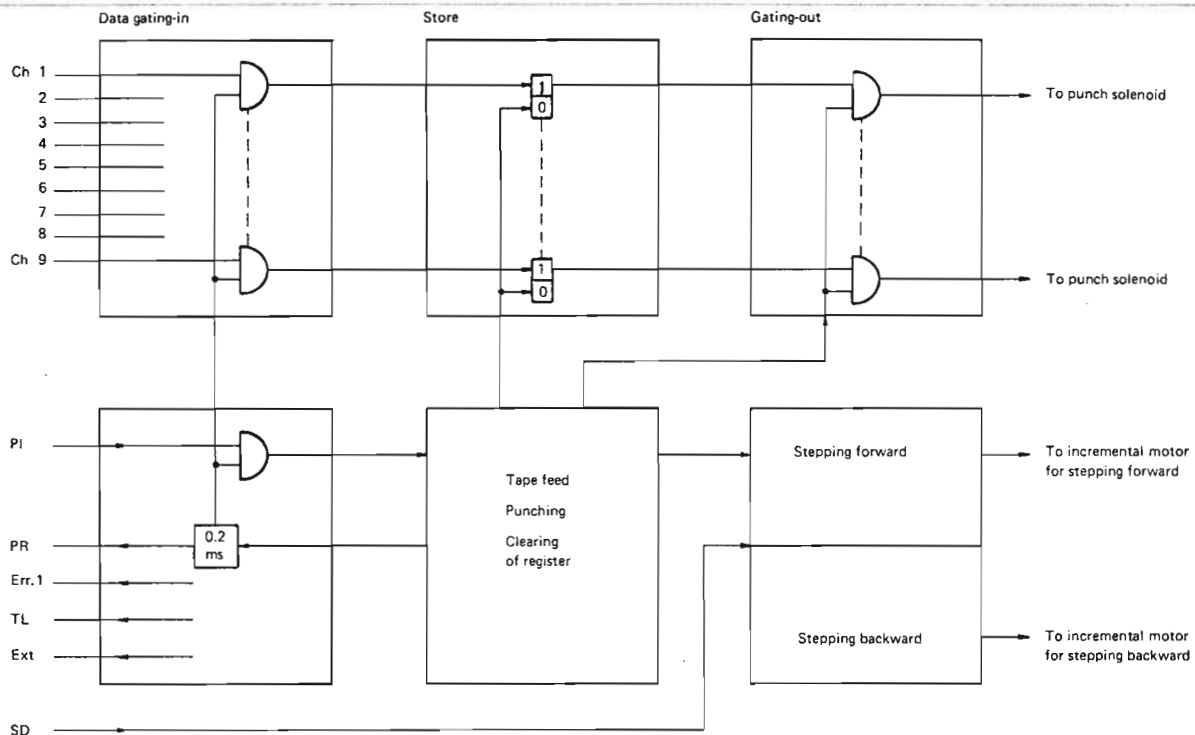

Fig. 3 Facit 4070 Block diagram

### Control Logic

Electronic circuitry on the standard printed circuit board in the tape punch can be divided into the functional blocks shown in Fig. 3. The blocks at the top represent the data path and the blocks underneath represent the circuits for synchronizing data input and start of punching cycle.

The data path circuits consist of a gating system for input data, a register for storing one character (one row) and output gates to the punching solenoids. The register is cleared between each character.

Data, Ch 1 – Ch 9, is transmitted on nine lines in parallel with a signal PI (Punch Instruction). Signals for holes (logical 1) correspond to a +3.5 to +12 V positive signal and for no-holes (logical 0) to –12 to +1.5 V. The signal PI (positive signal +3.5 to +12 V) initiates the punching cycle by starting circuits for advancing the tape. When signal PR (Punch Ready) is

emitted – the signal changes from +6 V to 0 V approximately 0.2 ms after PI – it indicates that data has been stored in the register, i.e. the data signals and the punching signal are no longer needed. The PR signal is low (0 V) during the remaining part of the punching cycle and can be used as a busy signal. When tape advance is completed, data is gated from the register to the punching solenoids and punching takes place. When punching is completed the PR signal goes high (+6 V), indicating that new data can be transmitted to the punch.

Stepping direction of the tape is controlled by the signal SD (Stepping Direction). A low level (–12 to +1.5 V) causes forward stepping and a high level (+3.5 to +12 V) causes backward stepping.

When the signal Err. 1 (Error) changes from a low to a high level it indicates that the tape is tightened or broken. While Err. 1 is present the PR-signal is low.

The signal TL (Tape Low) changes from a low to a high level when the tape on the supply flange has reached the point where a fresh coil is required. The sensing arm can be set to generate a signal when tape left on the flange is sufficient for an additional 1,000 to 10,000 characters.

The Ext-signal (0 V on pin 19 in the signal connector) is obtained when EXT-key on the control panel is depressed. This signal can be used for signalling manually to the data source or for resetting an error caused by a parity check error, or echo check error. When EXT-key is not depressed pin 19 is floating.

### Tape feed and punching

Fig. 4 shows part of the punching and feeding unit with solenoids and incremental feed motor.

The incremental feed motor advances the tape one row (one step) whereafter holes corresponding to data fed into the punch register are punched in the tape. Control signals for synchronizing the solenoids and incremental feed motor are generated on the standard printed circuit board.

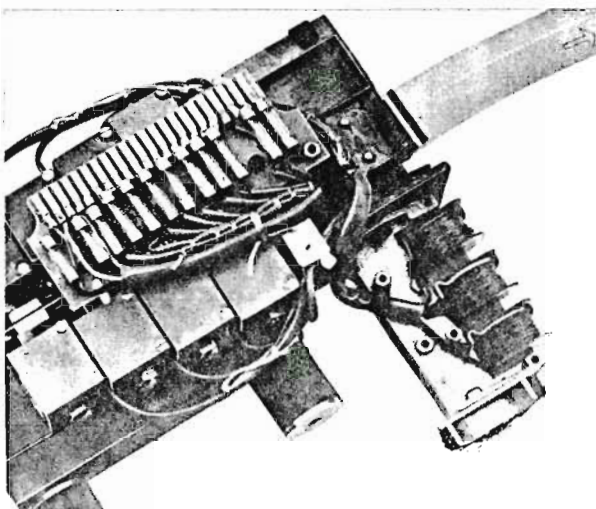

Fig. 4 The punching and feeding unit. This unit is also available as a separate unit (Facit 4071).

# SIGNAL DIAGRAMS

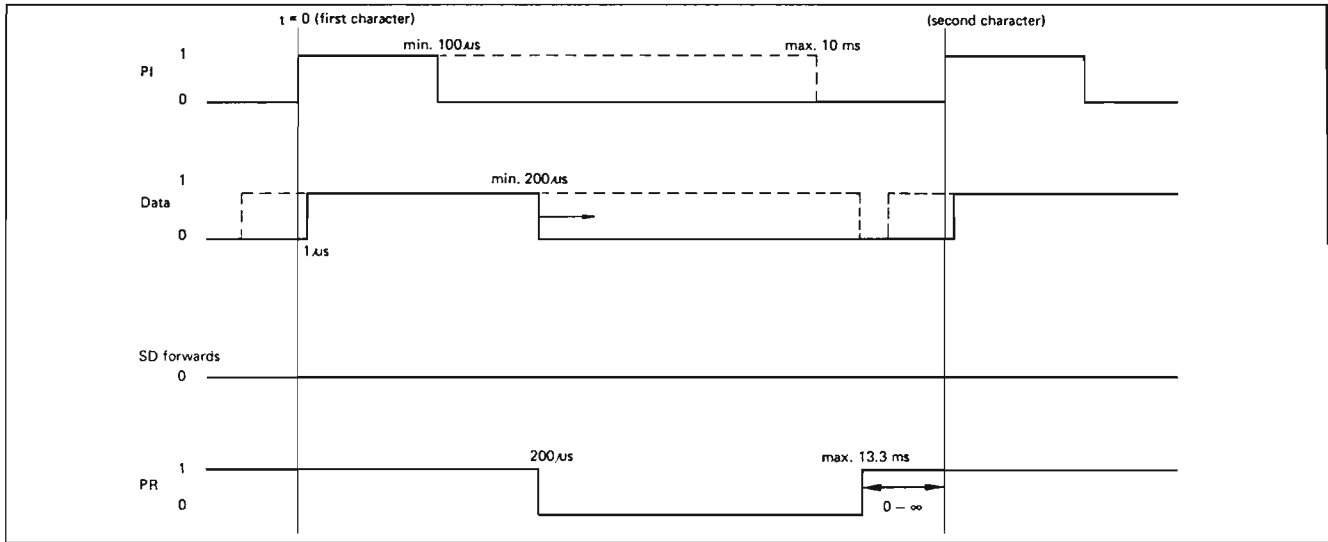

Fig. 5 Signal diagram for stepping forward

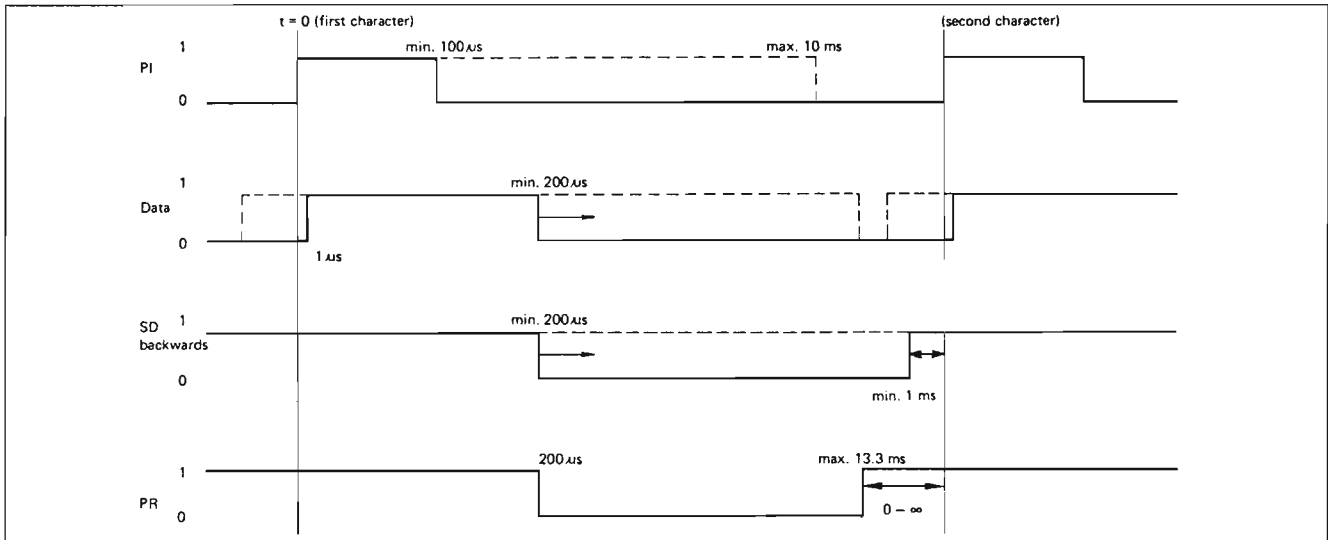

Fig. 6 Signal diagram for stepping backward

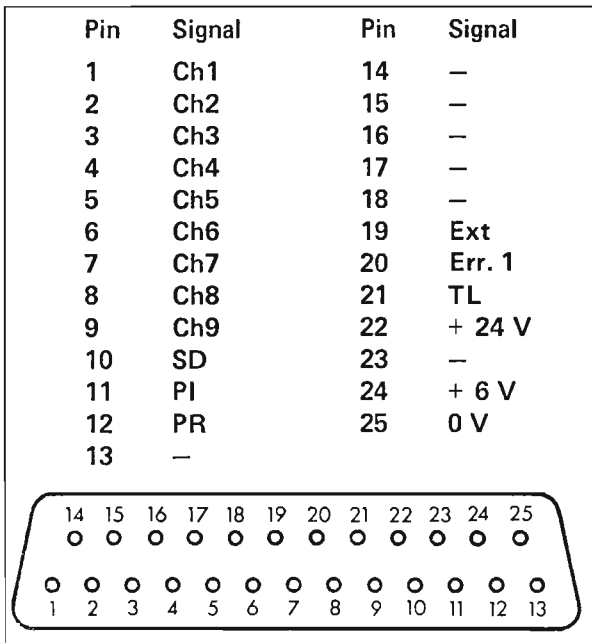

Fig. 7 Signal connector viewed from rear of tape punch

- Ch1 — Ch9 Data signals (channels 1 to 9)
- SD Stepping Direction signal
- PI Punch Instruction (start pulse) signal
- PR Punch Ready signal
- Err. 1 Error signal
- TL Tape Low Signal
- +24 V + 24 V from internal power supply (In DC version connected to + 24 V terminal in the power socket).
- + 6 V + 6 V from internal power supply
- 0 V Signal ground (Not connected to chassis ground.)

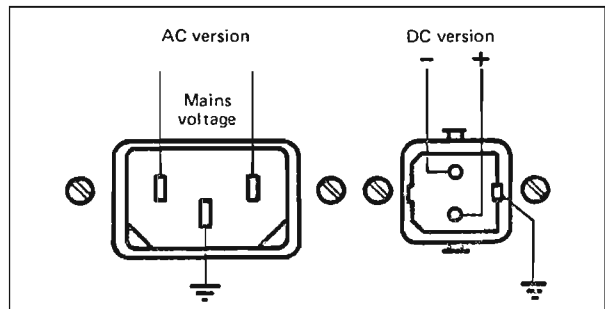

Fig. 8 Power sockets viewed from rear of tape punch

## SPECIFICATIONS

### GENERAL DATA

<b>Operation speed:</b>	Up to 75 rows per second.
<b>Tape feed:</b>	Asynchronous, externally controlled
<b>Feed accuracy:</b>	Complies with or exceeds ISO standards. Adjacent rows, 3% 10 rows, 1% 50 rows, 0.5%
<b>Backspacing:</b>	Up to 10 steps.
<b>Punch hole configuration:</b>	5–8 track ISO standard, 6 track typesetting.
<b>Tape widths:</b>	5 track tape, 11/16 inch (17.5 mm ± 0.1 mm) and 8 track tape, 1 inch (25.4 mm ± 0.1 mm). Alternatively 6 and 7 track, 7/8 inch (22.2 mm ± 0.1 mm)
<b>Thickness of tape:</b>	0.08–0.11 mm.
<b>Type of tape:</b>	ISO-standardized paper tape. Paper/Mylar/Paper tape.
<b>Hub:</b>	50.8–52.4 mm cores (2") as standard. Other types on request.
<b>Outer diameter of tape reel:</b>	Max. 203 mm (8").
<b>Reel capacity:</b>	Approx. 300 m which corresponds to about 120,000 rows.
<b>Store:</b>	Built in, stores one row (max. nine bits).
<b>Mark character:</b>	Customer-selected. Usually an all-hole delete character.
<b>Noise level with cover on (distance of 1 metre):</b>	Idling nil 5 ch/s punching one track 59 dB (B) 5 ch/s punching in all tracks 61 dB (B) 75 ch/s punching one track 75 dB (B) 75 ch/s punching in all tracks 77 dB (B)
<b>Dimensions:</b>	Length 432 mm (17"), width 220 mm (8 5/8") and height 198 mm (7 3/4"). Length with chad box 482 mm (19").
<b>Weight:</b>	AC version: 13.5 kg (30 lb). DC version: 9.5 kg (21 lb).

### INPUT SIGNALS

Signals shorter than 10  $\mu$ s at 6 V signal level are rejected as noise.

<b>Punch Instruction signal (PI):</b>	Min. pulse duration 0.1 ms. Input imp. min. 2.2 kohms. Logical 1: +3.5 V to +12 V. Rise time: Max. 10 $\mu$ s. Logical 0: -12 V to +1.5 V.
<b>Data signals (Ch1 – Ch9):</b>	Min. pulse duration 200 $\mu$ s. Ch1 to Ch8 – for tracks 1 to 8 – input imp. min. 22 kohms. Ch9 – for feed hole track – input imp. min. 22 kohms. Logical 1: +3.5 V to +12 V. Rise time: Max. 10 $\mu$ s. Logical 0: -12 V to +1.5 V.

**Stepping Direction signal (SD):** Input imp. min. 2.2 kohms.  
Forward direction: -12 V to 1.5 V.  
Backward direction: +3.5 V to +12 V.

### OUTPUT SIGNALS

<b>Punch Ready signal (PR):</b>	From logical 1 to logical 0 when information is stored in register. From logical 0 to logical 1 when punching is completed. Logical 1: +6 V. Output imp. 1 kohm. Logical 0: Max. +0.4 V. Max. 10 mA.
<b>Tape Low signal (TL):</b>	From logical 0 to logical 1 when TL is generated. Logical 1: +6 V via reed relay. y. Max. 10 mA. Logical 0: 0 V via 470 ohms.
<b>Error signals</b>	The signals Err. 1 and Err. 2 are generated simultaneously.
<b>Err. 1:</b>	From logical 0 to logical 1 when Err. 1 is generated. Logical 1: +5 V at 3 mA. Output imp. 100 ohms. Logical 0: Max. +6 V at 1 mA.
<b>Err. 2:</b>	From logical 0 to logical 1 when Err. 2 is generated. Logical 1: Min. +3 V at 3 mA. Logical 0: Max. +0.6 V at 2 mA. <b>Note:</b> The Err. 2 signal is available on the matching board only.
<b>External signal (Ext.):</b>	0 V when EXT-key is depressed. (Floating when not depressed.)

### SUPPLY VOLTAGE

<b>AC version:</b>	100/115/220/240 V $\pm 15\%$ $-10\%$ 50 to 100 Hz. Optional 400 Hz. Max. power consumption 200 W. Min. power consumption 50 W.
<b>DC versions:</b>	1. 24 V $\pm 20\%$ $-15\%$ Max. power consumption 180 W. Min. power consumption 2–5 W. <i>Both the AC version and the 24 V DC version are dimensioned to provide extra DC outputs for additional electronics of 1 A at +6 V and +24 V.</i>
	2. 48/60 V 48 V $\pm 8\%$ 60 V $\pm 10\%$ -4 -5 Max. power consumption 220 W Min. power consumption 40 W Extra power output 500 mA from +6 V.

### VARIANTS

	The following variants are available in table top and rack versions for AC or DC supply voltage.
<b>Facit 4070 for:</b>	5 and 8-track standard tape 6 and 7-track standard tape 6 track typesetting tape.

